

AL7E158-PS

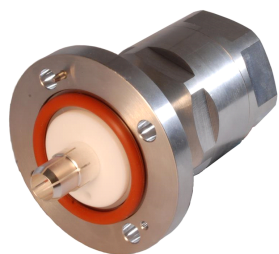

1-5/8 in EIA Flange for 1-5/8 in AVA7-50, AL7-50 and LDF7-50 cable

Product Classification

Brand	HELIAX®
Product Type	Wireless and radiating connector

General Specifications

Interface	1-5/8 in EIA Flange
Body Style	Straight
Mounting Angle	Straight

Electrical Specifications

Connector Impedance	50 ohm
Operating Frequency Band	0 – 2500 MHz
Cable Impedance	50 ohm
RF Operating Voltage, maximum (vrms)	2120.00 V
dc Test Voltage	6000 V
Outer Contact Resistance, maximum	1.50 mOhm
Inner Contact Resistance, maximum	1.50 mOhm
Insulation Resistance, minimum	5000 MOhm
Average Power	3.4 kW @ 900 MHz
Peak Power, maximum	90.00 kW
Insertion Loss, typical	0.05 dB
Shielding Effectiveness	-110 dB

Outline Drawing

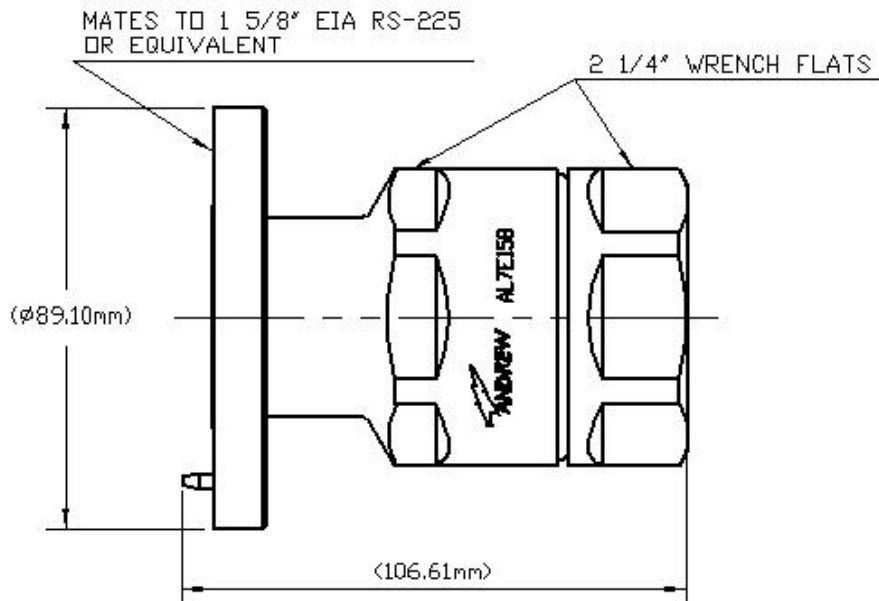

Mechanical Specifications

Outer Contact Attachment Method	Self-flare
Inner Contact Attachment Method	Thread-in stub
Outer Contact Plating	Trimetal
Inner Contact Plating	Silver
Attachment Durability	25 cycles
Interface Durability	50 cycles
Connector Retention Tensile Force	2224 N 500 lbf
Connector Retention Torque	13.56 N-m 120.00 in lb
Pressurizable	No

Dimensions

Nominal Size	1-5/8 in
Diameter	89.10 mm 3.51 in
Length	106.61 mm 4.20 in
Weight	1097.40 g 2.42 lb

Environmental Specifications

AL7E158-PS

Operating Temperature	-55 °C to +85 °C (-67 °F to +185 °F)
Storage Temperature	-55 °C to +85 °C (-67 °F to +185 °F)
Immersion Depth	1 m
Immersion Test Mating	Mated
Immersion Test Method	IEC 60529:2001, IP68
Water Jetting Test Mating	Mated
Water Jetting Test Method	IEC 60529:2001, IP66
Moisture Resistance Test Method	MIL-STD-202, Method 106
Mechanical Shock Test Method	MIL-STD-202, Method 213, Test Condition I
Thermal Shock Test Method	MIL-STD-202F, Method 107G, Test Condition A-1, Low Temperature -55 °C
Vibration Test Method	MIL-STD-202, Method 204, Test Condition B
Corrosion Test Method	MIL-STD-1344A, Method 1001.1, Test Condition A

Standard Conditions

Attenuation, Ambient Temperature	20 °C 68 °F
Average Power, Ambient Temperature	40 °C 104 °F

Return Loss/VSWR

Frequency Band	VSWR	Return Loss (dB)
45–1000 MHz	1.04	35.00
1010–2200 MHz	1.04	35.00
2210–2500 MHz	1.07	30.00

Regulatory Compliance/Certifications

Agency	Classification
RoHS 2011/65/EU	Compliant by Exemption
ISO 9001:2015	Designed, manufactured and/or distributed under this quality management system
China RoHS SJ/T 11364-2014	Above Maximum Concentration Value (MCV)



* Footnotes

Immersion Depth	Immersion at specified depth for 24 hours
Insertion Loss, typical	0.05vfreq (GHz) (not applicable for elliptical waveguide)